

The piston is composed of two elements:

- lower cylinder element <B> with inserted the higher ram element <2>.
- higher cylinder element <A> with inserted the lower ram element <1>.

### Assembly phase sequence

- I** Suspend the lower cylinder element <B> with the special hangers <3> and lean it on its base.
- II** Unscrew and remove the protection cover <4>.
- III** Hang up the lower cylinder element <2> with its hook and unscrew for about 10-15 cm.
- IV** Apply the hangers <6> on the ram part that juts out, so that it can not re-enter, and then unscrew and remove the protection cover of the cylinder <7>.
- V** Apply the hangers <3> to the higher cylinder element <A>, lift the cylinder and line it up in the assembly position, and then remove the rubber cover <8> and unthread the ring of ram support <9>.
- VI** Apply the hangers <10> to the higher cylinder element <1>, and then make the split ram as indicated in the instruction 09172/G.
- VII** Remove the hangers from the ram and then lower the cylinder, carefully lining up the two millings <11> e <12> which indicate the thread beginning.
- VIII** Make the Split Cylinder as indicated in the instruction 09172/G.

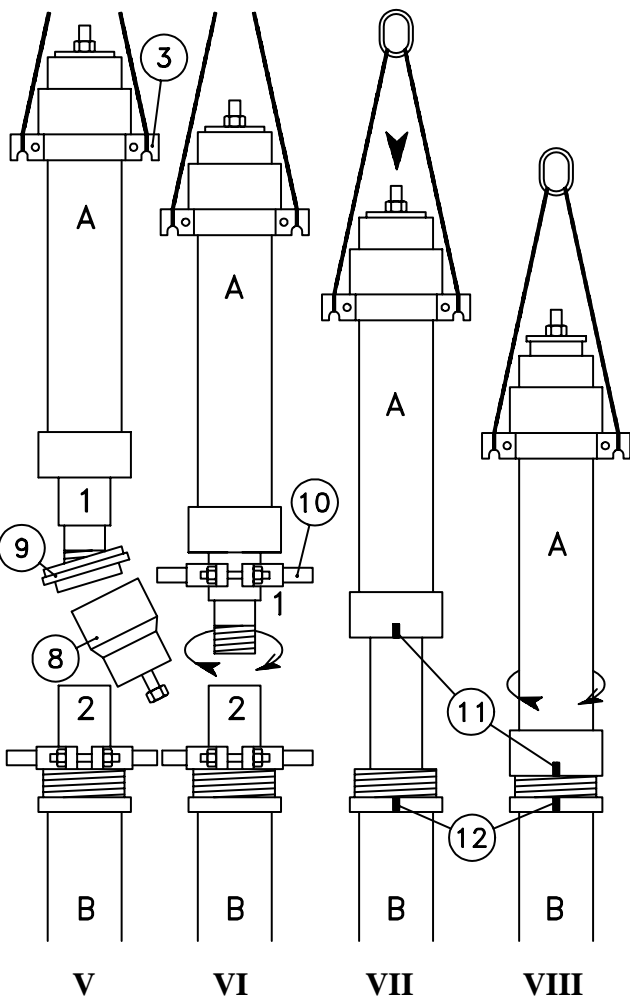

**SPLIT RAM  
ASSEMBLY**



**Start Elevator Srl**

09 171 / G

rev. 0

1/1

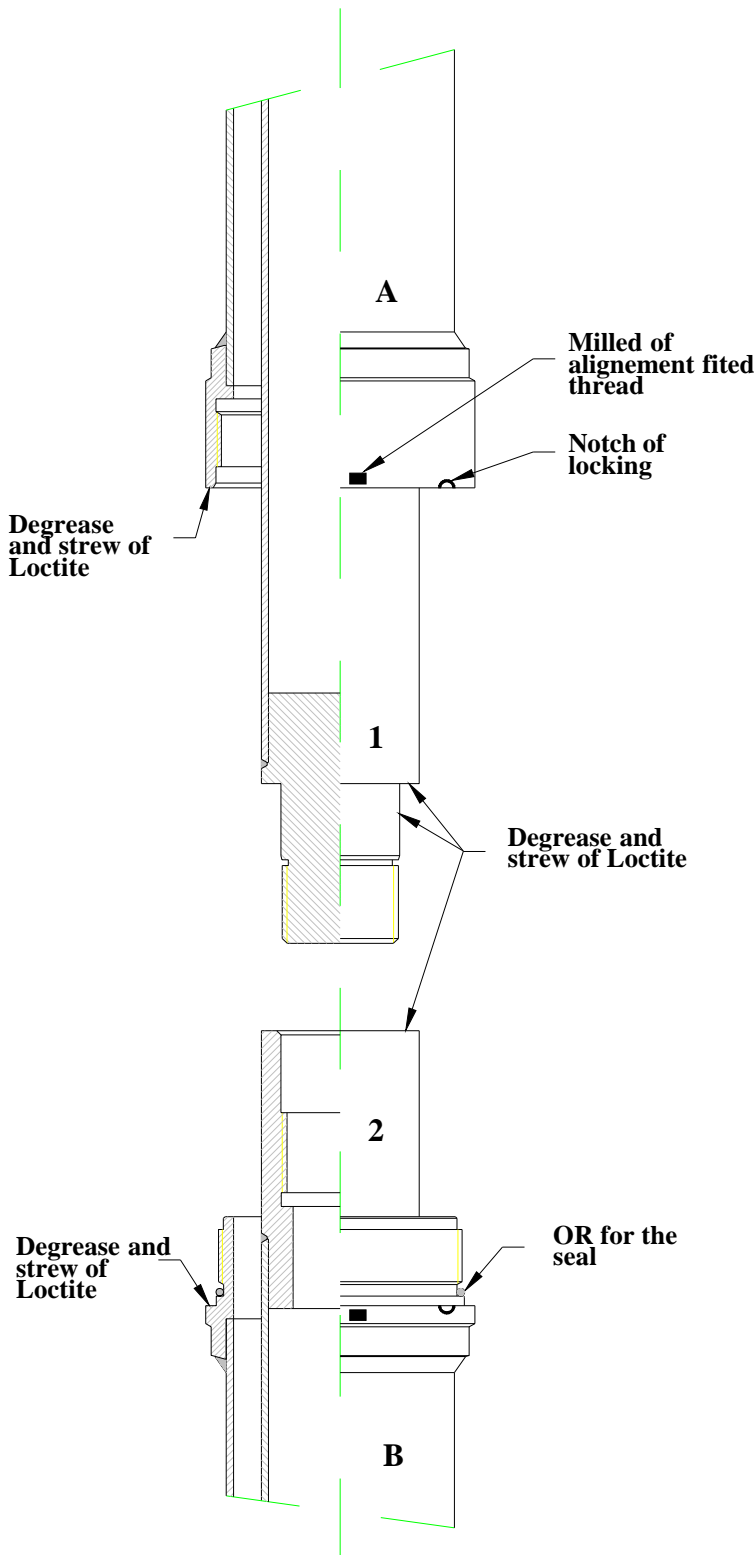

## JOINING RAM 1-2

Check that the joinings are perfectly clean and greased.

Otherwise clean perfectly both male and female and grease plentifully.

**The presence of any foreign matter may cause the binding of the thread.**

Screw without forcing, and constantly checking alignment.

Stop one cm. before completion, degrease perfectly the ledge, then spread with Loctite.

Continue screwing operation and, if necessary, using the bracket, give one firm sharp blow for final securing.

Control with the hand that, of the joining point, there is not even the minimum step and, if necessary, remove it with the fine emery cloth.

## JOINING CYLINDER A-B

Check that the joinings are perfectly clean and greased.

**The presence of any foreign matter may cause the binding of the thread.**

Check that the sealing "O" ring is correctly positioned.

Check the alignment of the milling of the thread adit, then lower and screw without to force, checking the alignment of two pieces, one cm. before completion.

Degrease perfectly the two ledges and spread with Loctite

Screw with force to obtain the perfectly coincidence of the notches "O".

**WAIT 24 HOURS BEFORE TO INTRODUCE OIL IN THE PISTON.**

**JOINING OF THE PISTON IN TWO PIECES  
ISTRUCTIONS  
TYPE 60-70-80-90-100-110-120-130-150**



**Start Elevator Srl**

09 172 / G

rev. 1

1/1